



**DAWSON**  
CONSTRUCTION PLANT LTD



THE NEXT STEP IN DIGITAL CONTROL

electrical switching

# HPH1200e PILING HAMMER



**NEW**  
DIGITALLY CONTROLLED  
DROP WEIGHT

- Fast hammer blow rate for rapid pile penetration
- Full energy monitoring on screen
- Full history of hammer performance
- Highly reliable and robust electrical switching
- Intelligent stroke control
- Very few serviceable parts, with on screen fault diagnostics
- Easily maintained by Diesel / Mechanical fitter
- Cushion block irons out peak stresses
- Very efficient energy transfer

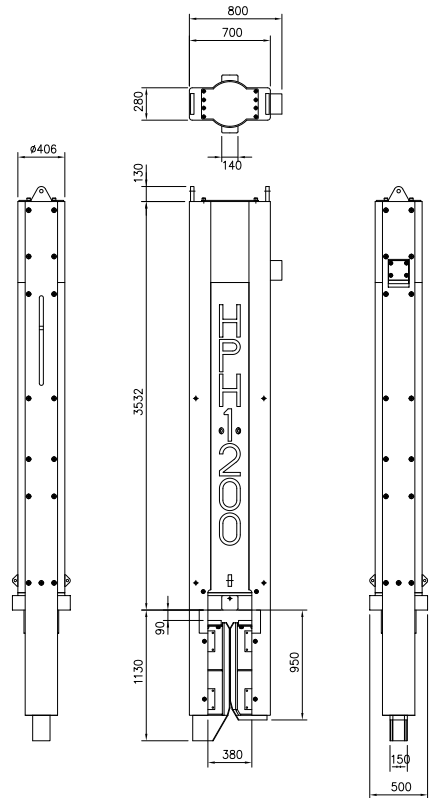

## HPH1200 HAMMER

SPECIFICATION	UNITS	HPH1200
RAM WEIGHT	kg	1,040
	lbs	2,300
IMPACT VELOCITY	m/s	4.76
	ft/s	15.60
MAXIMUM ENERGY TRANSFERED TO PILE	KNm	12.00
	ft lb	8,680
MINIMUM ENERGY TRANSFERED TO PILE	KNm	6.2
	ft lb	4629
BLOW RATE	bpm	80-120
LENGTH - LEAD MOUNTED	mm	3,800
	in	150
MINIMUM WIDTH OF BODY	mm	406
	in	15.98
WEIGHT - LEAD MOUNTED	kg	3,000
	lbs	6,600
WEIGHT - WITH SHEET PILE LEG GUIDES + SPREADER PLATE	kg	3,000
	lbs	6,600

PILE CONFIGURATIONS  
 . ALL LARSEN SHEET PILES IN SINGLES/PAIRS WITH STD LEG INSERTS.  
 . ALL FRODINGHAM SHEET PILES IN SINGLE/PAIRS WITH STD LEG INSERTS.  
 . H-PILES 305x305 UPWARDS WITH STD LEG INSERTS  
 . H-PILES SMALLER THAN 305x305 WITH SPECIAL LEG INSERTS.  
 . CONCRETE & TIMBER PILES UP TO 350x350 WITH STD LEGS  
 . TUBULAR PILES UPTO Ø410 WITH STD LEGS  
 SPECIAL LEGS & INSERTS AVAILABLE ON REQUEST



## POWERPACK

SPECIFICATION	UNITS	DAWSON
DIESEL ENGINE POWER	kW	93
	rpm	2100
HYDRAULIC SYSTEM PRESSURE	bar	240
	psi	3480
OIL FLOW RATE	L/min	75
SIZE - LENGTH x WIDTH x HEIGHT	m	2.85 x 1.34 x 2.26
	in	112 x 53 x 89
WEIGHT	kg	3000
	lbs	6,600
FUEL CAPACITY	litres	275
FUEL CONSUMPTION @ 60%	litres / hour	15.2

# HPH1200e PILING HAMMER

DAWSON CONSTRUCTION PLANT  
CHESNEY WOLD,  
BLEAK HALL,  
MILTON KEYNES,  
MK6 1NE  
ENGLAND

TEL. +44 1908 240300  
FAX. +44 1908 240222  
EMAIL. DAWSON@DCPUK.COM

www.dcpuk.com

Dawson Construction Plant has developed an industry leading, robust and simple, electronic control system that **constantly** monitors the drop weight position. This constant monitoring allows the switching timing on the main hydraulic spool to be trended to continually optimise hammer performance throughout varying piling conditions, such as:

- 1 – Hard driving with pile recoiling
- 2 – Soft driving with a running pile
- 3 – Cold hydraulic oil on start up
- 4 – Raking piles



DATA CAN BE  
RECORDED TO A  
LAPTOP



INTERFACE SCREEN MOUNTED ON POWER PACK

With constant drop weight position monitoring, the velocity of the drop weight is also known, therefore energy output can be accurately measured and is displayed to the operator on the powerpack interface screen. This information can be recorded direct to a laptop via a Dawson software interface, and can be saved in standard spreadsheet formats, giving a blow by blow account of every pile driven and a day to day productivity record.

## MAIN PAGE

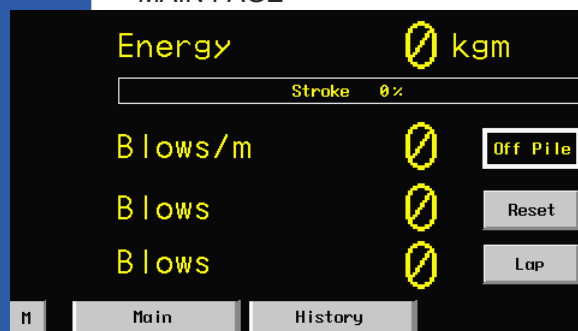

TYPICAL SCREEN SHOTS

## HISTORY PAGE

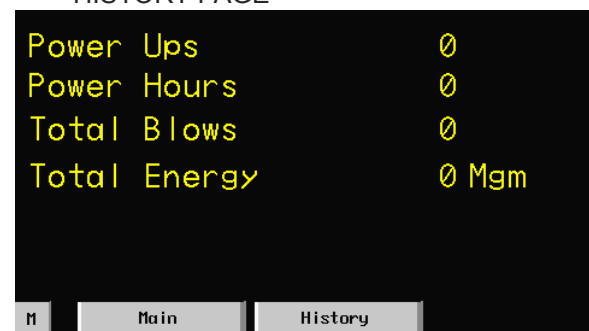

WORLDWIDE  
DEALER  
NETWORK

GLOBAL  
SUPPLY,  
LOCAL  
SUPPORT.

The main screen displays bar graphs showing hammer stroke & hydraulic oil temperature.

An Off Pile indicator confirms when the hammer is securely seated on the pile, and allows piling to commence.

There are numerical read outs showing blows per minute, energy per blow and total blows. The lower reading shows blows in LAP cycle. (Measuring blows per increment). The units can be changed from imperial to metric.

The history screen provides information on the total number of start ups / total hours / total blows and total energy through out the life of the hammer.