

safety lifting equipment

ERRRS

3.5t

5t

7.5t

10t

25t

40t



owners manual  
operators instructions  
spare parts list  
safety precautions  
maintenance

euro ratchet release shackle

DAWSON CONSTRUCTION PLANT LTD.  
CHESNEY WOLD,  
BLEAK HALL  
MILTON KEYNES  
MK6 1NE, ENGLAND  
TEL: +44 (0) 1908 240300  
FAX: +44 (0) 1908 240222  
EMAIL: JON@DCPUK.COM



**DAWSON**  
CONSTRUCTION PLANT LTD

www.dcpuk.com

# preface

This manual is used to familiarise you with safety, assembly, operation, adjustment, troubleshooting, and maintenance. Read and follow the recommendations in this manual to ensure safe and efficient operation.

We want you to be completely satisfied with your new product, feel free to contact your local authorized service dealer for help with service, replacement parts, or any other information you may require. If you need assistance in locating a dealer, visit our web site at [www.dcpuk.com](http://www.dcpuk.com) or call customer service at +44 (0) 1908 240300.

Whenever you contact your authorised service dealer, always have the model number and serial number of your product available. These numbers will help provide exact information about your specific product. You will find the model and serial numbers on an ID plate located on the product.

The descriptions and specifications in this manual are subject to change without notice. Dawson reserves the right to improve products. Some product improvements may have taken place after this manual was printed.



# table of contents

Preface	2
Table of Contents	3
Introduction & Features	4
Method of operation	5
Lifting piles correctly	6-7
Safety checklist	8-9
Installation diagram - on a steel column	10
Training	11
Maintenance	12
Technical Specs	13-14
Parts list - 3.5, 5, 7.5, 10 , 25t shackle	15
Parts list - 40t shackle	16-17
A guide to changing the Pawl, Pawl spring and belt on a Dawson ratchet release shackle	
Under separate cover:	-
· Individual Test Certificate & Thorough Examination if required.	
· E.C. Declaration of Conformity	

# introduction

This robust lifting shackle was contractor designed and developed over many years of site use and abuse.

The use of these shackles compliments the “Feet on the Ground” approach to steel erection and pile installation. There is no need for site operatives to go into a dangerous position to release the lifting attachment.

The shackle is stiffened to resist spreading of the forks when lifting at 90° to the axis of the lift (see “Safety Check List”).

The Ratchet Shackle is designed for lifting steel through standard bolt holes or other units of lift having a suitable hole through which the pin can be conveniently and safely engaged.

## FEATURES

Robust high strength cast steel body.

Pin mechanism concealed for maximum protection.

Pin mechanism easily detachable for maintenance.

Can be used for lifting columns, pipe piles, sheet piles & steel fabrications.

Heavy web stiffening to withstand side lift (i.e. 90° to the axis imposed when lifting from the horizontal. (See “Safety Check List” for correct working practice).

Independently proof load tested to twice Safe Working Load. Test certificates are supplied with each shackle.

Super safe design which avoids accidental release.

Positive pin release at the proper time.

# method of operation

1. With the pin retracted, slide the shackle over the head of the unit to be lifted until the pin is approximately over the lifting hole. Press the ratchet pawl down with the thumb of one hand and turn the release nut of the shackle with the other hand.

Turning in a clockwise direction will propel the pin through the lifting hole. The indicator bar should finish flush with the release nut which means that the pin is fully entered into the opposite side of the shackle.

2. Two soft ropes should be attached to the small 'D' shackles at each end of the toothed belt.

3. The unit may then be lifted. It is prudent to tie the ends of the shackle release ropes to the bottom of the unit of lift to prevent the ropes becoming snagged or being caught by the wind and become inaccessible.

4. After securing the unit of lift, the shackle is released by pulling the release ropes first one way then the other five or six times. The ratchet action withdraws the pin. The stroke of the pull is limited by the 'D' shackles at the end of the toothed belt. (450mm maximum length).

# lifting piles correctly

## LIFTING PAIRS OF PILES

When lifting sheet piles in pairs it is necessary to use a pair of shackles.

The ring at the top of the sling can be hooked directly onto a standard crane hook block, D shackle or fork anchor. The sling also enables the shackles to be turned to fit opposite faces of box or tube piles using the standard sling and shackles.

Shackles can also be fitted onto a solid steel cross head according to customers requirements.



Downrate in accordance with national codes

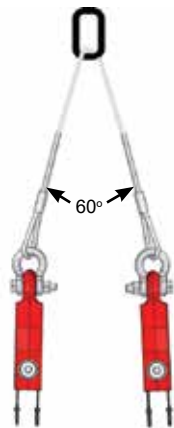

# continued-lifting piles correctly

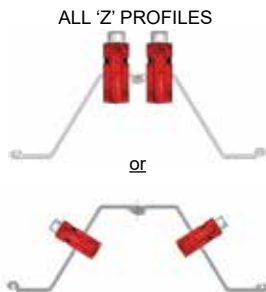
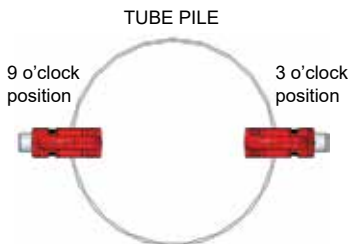
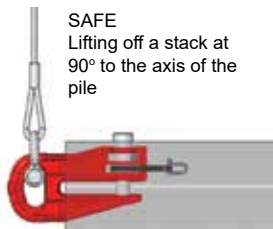
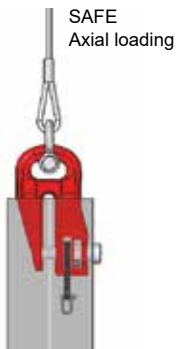

# safety check list

## 1) PRE-INSTALLATION CHECKS

Prior to installing a shackle onto any steelwork, check the following:

- a. Establish the weight of the lift involved and ensure a shackle with appropriate Safe Working Load is being used.
- b. Ensure the lifting hole is at the correct distance from the top of the steelwork .  
i.e. 150mm for a 150mm throat depth shackle, 250mm for a 250mm throat depth shackle or 300mm for a 300mm throat depth shackle.



**Incorrect hole placement in steelwork may cause shackle failure!**

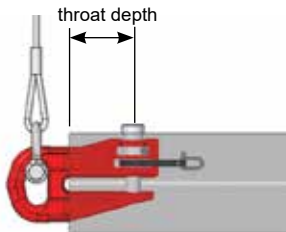

- c. The lifting hole should be neatly drilled or punched and of a suitable size to suit the plunger.
- d. The Safe Working Load rating of any shackle is based on a purely tensile (axial) load. When lifting steelwork from horizontal to vertical or the reverse, remember that the shackle becomes de-rated by 50%.  
i.e. a 10 tonne S.W.L. Ratchet Shackle should only be loaded to 5 tonne at the start of a horizontal lift.



## continued - safety check list

- 2) Ensure that the pin has gone through both sides of the shackle body.
- 3) Do not modify the lifting shackles or any part of the lifting apparatus. Keep the burning torch well clear!
- 4) Keep the release mechanism well lubricated.
- 5) Care should be taken to avoid the pull ropes getting snagged.
- 6) The angle between the two legs of the lifting strap, where applicable should not exceed 90°.
- 7) Ensure that all appropriate laws, bye-laws and regulations are complied with.



**KEEP FINGERS OUT OF THE SHACKLE THROAT AT ALL TIMES. (GLOVES SHOULD BE WORN.)**



**DO NOT USE SHACKLE IN TEMPERATURES BELOW -15°C (5°F)  
CONSULT MANUFACTURE FOR FURTHER INFORMATION ON LOW TEMPERATURE SOLUTIONS.**

# installation diagram

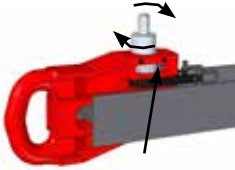

## 1. Insert pin.

With the pin retracted, slide the shackle over the material to be lifted until the pin is approximately over the lifting hole. Press the ratchet pawl down with thumb of one hand and turn the release nut of the shackle clockwise with the other hand. Continue turning until the pin has gone through the hole in the material to be lifted and into the opposite of the shackle. The indicator bar should be flush with the face of the release nut.



## 2. Hoist to position

Two soft ropes should be attached to the 'D' shackles at each end of the toothed belt. The material may then be lifted. It is prudent to tie the ends of the shackle release ropes to the bottom of the material (2a) to prevent the ropes from becoming snagged or being caught in the wind and becoming inaccessible.

### 2a. Tie release ropes



## 3. Release shackle after material has been secured.

After lifting & securing the material, the shackle is released by pulling the release ropes first one way then the other, five or six times. The ratchet action withdraws the pin. The stroke of the pull is limited by the 'D' shackles at each end of the toothed belt (450mm maximum length).

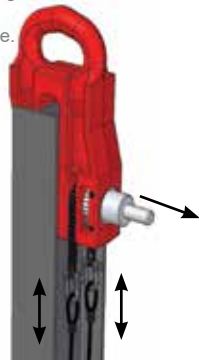

# training

Before allowing operators to use the Shackle, it is important to ensure they have received basic training in lifting and control of heavy loads.

It is strongly recommended that the following areas are covered:

1. Basic safety in lifting operations
2. Supervision during lifting operations
3. Detailed instruction on how the Euro Shackle operates
4. Safety Features of the Euro Shackle
5. Dangers and Mal-practices
6. Correct choice of Euro shackle for the job

# maintenance

The Shackle is manufactured from high quality material and assembled in a manner designed to offer long service with a minimum of maintenance.

In order to preserve the product in this state, it is necessary to ensure that it is not mis-used or used for purposes outside its recommended use and to carry out regular inspection and servicing.

The shackle body should be checked regularly for distortion arising from overload - **if bent - [bin](#)**.

The pin should be checked for smooth travel and light oiling applied at moving surfaces.

If the product does not operate perfectly, contact the manufacturer for advice, or return for immediate attention.

Each unit is issued with a test certificate.

If any parts of the shackle are replaced with non standard parts or in a non approved manner, the certificate is no longer valid.

Replacement of any load bearing components requires a re-test to twice safe working load.

# technical spec

	MODEL No.										
	681	682	683	684	686	687	688	689	692A	693A	6961A/A
A	Ø20	Ø20	Ø24	Ø24	Ø27	Ø35	Ø35	Ø27	Ø27	Ø35	Ø60
B	158	258	158	258	258	158	258	158	303	303	250
C	277	377	277	377	377	277	377	277	360	360	423
D	78	78	78	78	78	78	78	78	80	80	120
E	35	35	35	35	35	35	35	35	40	40	50
F	30	30	30	30	30	30	30	30	32	32	50
G	160	160	160	160	160	160	160	160	202	202	231
H	55	55	55	55	55	55	55	55	60	60	80
J	R17.5	R17.5	R17.5	R17.5	R17.5	R17.5	R17.5	R17.5	R20	R20	R27
WEIGHT	15kg	19kg	15kg	19kg	19kg	15kg	19kg	15kg	22kg	22kg	48kg

## Model No. - Size

681 - 3.5T ERRS 150 Throat

682 - 3.5T ERRS 250 Throat

683 - 5T ERRS 150 Throat

684 - 5T ERRS 250 Throat

686 - 7.5T ERRS 250 Throat

687 - 10T ERRS 150 Throat

688 - 10T ERRS 250 Throat

689 - 7.5T ERRS 150 Throat

692A- 7.5T ERRS 300 Throat

693A- 10T ERRS 300 Throat

6961A/A - 25T ERRS 250 Throat

6962A - 40T ERRS 250 Throat

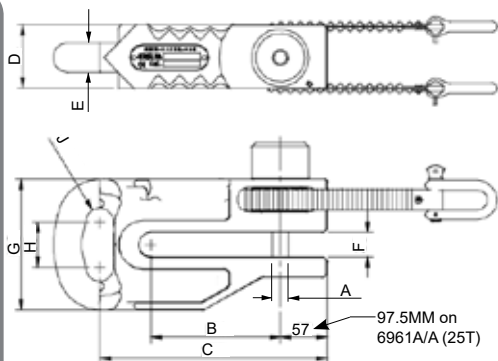

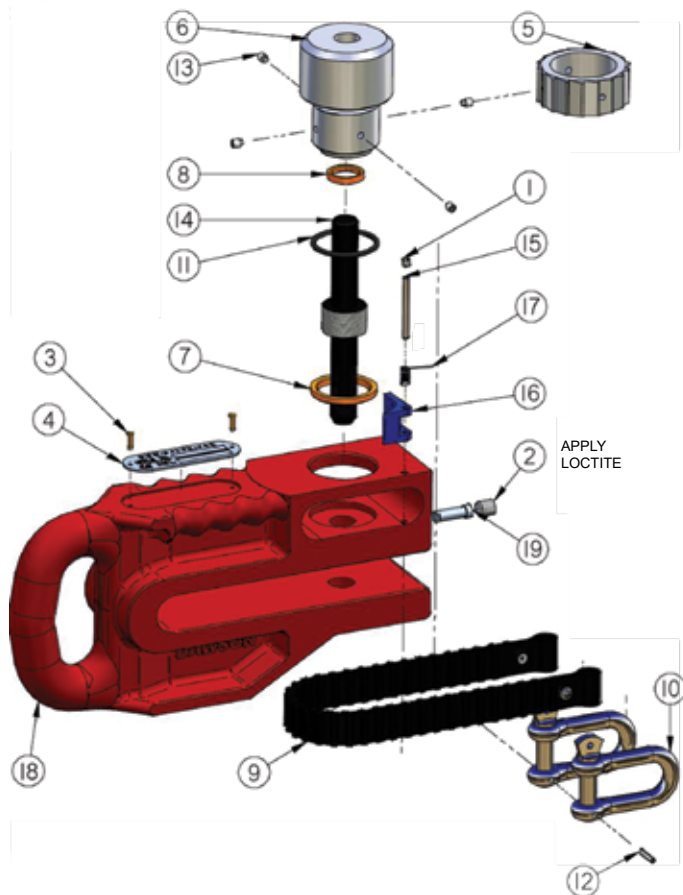

GENERAL ASSEMBLY

# parts list

Item No.	Qty	Part Name	MODEL No.										
			681	682	683	684	686	687	688	689	692A	693A	6961A/A
1	1	Socket Set Screw M6 x 6	0M06.006.05										
2	1	Socket Set Screw M12 x 12	0M12-012-05										
3	2	No.6 x 1/2" Rivet	1-204-00-01										
4	1	Shackle ID Plate	5938										
5	1	Ratchet Collar Machined	604					642	642	604	604	642	694
6	1	Release Nut	605					643	643	605	605	643	690
7	1	Nylon Ring	606	606	606	606	606	644	644	606	606	644	692
8	1	Nylon Buffer Stop	607										6932R
9	1	Ratchet Belt Assy	608A										6936A
10	2	Small D Shackle	609										
11	1	O-Ring	610										697
12	2	Spring Pin	0M04.020.22										
13	4	Dog P't Grub Screw	0M06.008.16										
14	1	Threaded Pin	621	621	671	671	601	641	641	601	601	641	674
15	1	Pivot Pin	626										
16	1	Pawl	627										
17	1	Pawl Spring	628										
18	1	ERRS Main Body	661/A	666/A	662/A	667/A	668/A	664/A	669/A	663/A	678	679	670
19	1	Guide Peg	672										

# parts list - 40t shackle

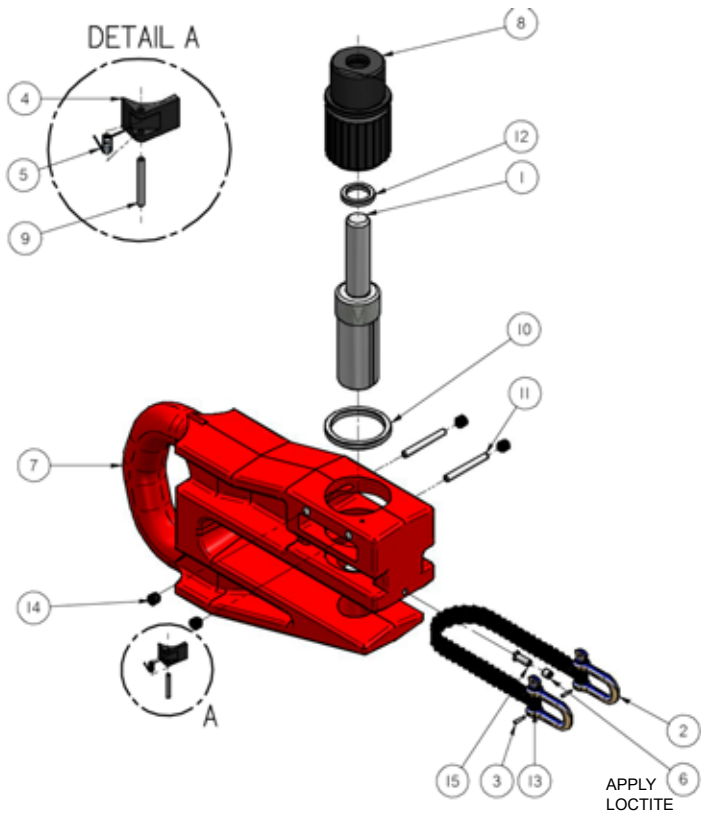

40T ERRS 250 THROAT - 6962A



# continued - parts list

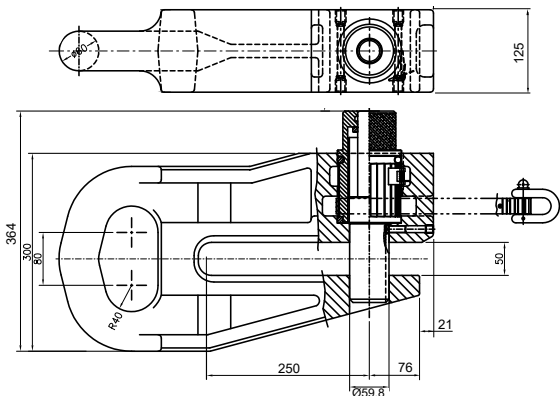

GENERAL NOTE: WEIGHT 67kg

Item No.	Quantity	Part Name	6962A
1	1	Threaded Pin	6912
2	2	Small D Shackle	609
3	2	Spring Pin	0M04.020.22
4	1	Pawl	627
5	1	Pawl Spring	628
6	1	M12x12 Flat Nose Grub Screw	0M12.012.05
7	1	Main Body	6902/A
8	1	Release Nut	6920
9	1	Pivot Pin	6923
10	1	Bearing Washer	6930
11	2	Location Bar	6931
12	1	Nylon Buffer Stop	6932
13	1	Ratchet Belt Assembly	6936A
14	4	Plain Cup Point Set Screw	0M16.016.05
15	1	Guide Pin	6942

40T ERRS 250 THROAT  
GENERAL ASSEMBLY

MODEL No. 6962A

euro ratchet release shackle



A GUIDE TO CHANGING THE PAWL,  
PAWL SPRING AND BELT ON A DAWSON  
RATCHET RELEASE SHACKLE



## 01

The Pawl and its return spring may require changing if badly worn or generally damaged.

**SAFETY GLASSES SHOULD BE WORN. THE SPRING IS UNDER COMPRESSION AND MAY FLY OUT DURING THIS PROCEDURE!**

First, remove the M6 socket set screw.



## 02

Note the arrangement of pawl and spring. Slide the pivot pin out to allow removal of the pawl and spring.



## 03

Insert the new pawl. Hold the spring in place with pliers and gently tap home the pivot pin through pawl and spring. Note that the short arm of the pawl is uppermost and the "legs" of the spring are between the pawl and the body of the shackle.



## 04

Tap home the pivot pin with a small pin punch.



## 05

Finally, refit and tighten the socket set screw. Carefully check the action of the pawl before allowing the shackle back into service.



## 06

**REMEMBER TO WEAR EYE PROTECTION!!!**

Photo shows:  
Ratchet release shackle with new belt kit including new "D" shackles with roll pins.



## 07

Cut, remove and discard the old belt. Thread the new belt through the gap between the shackle body and the pawl collar.



## 08

The flush head of the pop rivet is towards the pawl collar and the head of the screw in any "D" shackle should be towards the middle of the shackle.



## 09

Fit the new "D" shackle(s), passing the screw through the loop in the belt as shown.

Tighten the screw, aligning the 4mm diameter holes and tap in the roll pin until flush.

**REMEMBER TO WEAR EYE PROTECTION!!!**

Check the action of the belt and ratchet before allowing the shackle back into service.



D.C.P. RESERVES THE RIGHT TO DISCONTINUE EQUIPMENT AT ANY TIME, OR CHANGE SPECIFICATIONS OR DESIGNS WITHOUT NOTICE OR INCURRING OBLIGATIONS

INNOVATIVE PILING EQUIPMENT

HYDRAULIC PILING HAMMERS

EXCAVATOR MOUNTED VIBRATORS

EXCAVATOR MOUNTED DRILLS

QUIET, VIBRATIONLESS PUSH-PULL PILING

PILE EXTRACTION

SHEET PILE GUIDE FRAMES

SHEET PILE CAPPING SYSTEMS

CFA CLEANERS

PILE POINTS & SPLICERS

SAFETY HANDLING / LIFTING EQUIPMENT

SHEET PILE THREADERS

euro ratchet release shackle  
3.5t - 5t - 7.5t - 10t - 25t - 40t

DAWSON CONSTRUCTION PLANT LTD.  
CHESNEY WOLD,  
BLEAK HALL  
MILTON KEYNES  
MK6 1NE, ENGLAND  
TEL: +44 (0) 1908 240300  
FAX: +44 (0) 1908 240222  
EMAIL: JON@DCPUK.COM



[www.dcpuk.com](http://www.dcpuk.com)